

SIMMERRING RADIAMATIC® R 58

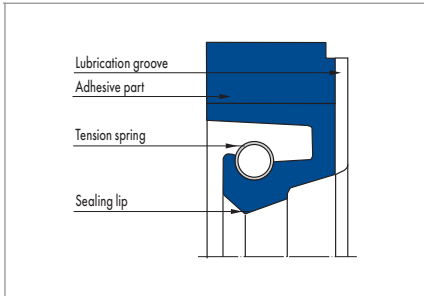

PRODUCT DESCRIPTION

Simmerring with a fabric reinforced static part that is securely joined to the elastomer sealing lip. The sealing lip is also pre-loaded with a garter spring.

PRODUCT ADVANTAGES

The sealing ring has a groove around the circumference to facilitate additional lubrication from the outside. The Simmerring Radiamatic R 58 was developed for the special requirements of grease-lubricated bearings in mill manufacture.

- Particularly robust static part
- Lasting radial contact pressure
- Highly wear-resistant

APPLICATION

- Rolling mills

MATERIAL

| Sealing lip | Static part | Tension spring |
|-------------|-----------------------------------|----------------|
| 80 NBR B241 | Impregnated cotton fabric B4 B248 | ST 1.4571 |

OPERATING CONDITIONS

| | |
|------------|----------|
| Pressure p | 0,05 MPa |
|------------|----------|

| | |
|-----------------|--------|
| Running speed v | 15 m/s |
|-----------------|--------|

| Medium/ Temperature | 80 NBR B241 |
|------------------------|--------------------|
| Mineral oils | |
| Water | +5 °C ... +100 °C |
| Mineral greases | -30 °C ... +100 °C |
| Rolling oil emulsion | on enquiry |

Other media on enquiry. Application parameters are recommended values, do not utilise all parameters simultaneously.

DESIGN NOTES

Please observe our general design notes in → Technical Manual.

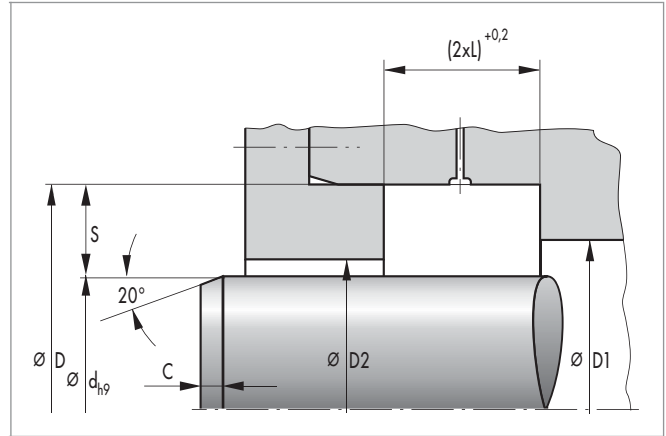

Surface quality

| Peak-to-valley heights | R _a | R _{max} |
|------------------------|----------------|------------------|
| Sliding surface | ≤0,6 µm | ≤2,5 µm |
| Housing | ≤4,0 µm | ≤15,0 µm |

The contact area is machined by plunge grinding, i.e. without feed. The surface hardness must be approx. 60 HRC (depth of hardening min. 0,5 mm). With increasing circumferential speed the contact area should be manufactured with increasing peak-to-valley heights R_a. The surface should not be too smooth so that an adequate film of lubricant can form. Recommended value: R_{a min} = 0,1 µm. Percentage contact area M_r >50% to max. 90% at cutting depth c = Rz/2 and reference line C ref = 0%. Abrasive surfaces, ridges, scratches and blow-holes are to be avoided.

Tolerances

| Nominal Ø D | D | d |
|-------------|-------------|----|
| <500 mm | H8 | h9 |
| ≥500 mm | +0,0004 x D | h9 |

Overall eccentricity

The permissible overall eccentricity (static and dynamic eccentricity) between shaft and housing is dependent on the seal profile and circumferential speed. If necessary, we will provide recommended values.

FITTING & INSTALLATION

For Simmerring Radiamatic R 58 an axially accessible housing is necessary, as the rings must have low inclination. The Radiamatic R 58 rings are supplied with oversize seal width. For reliable function the Radiamatic R rings must be axially compressed to the dimension "L". An open housing with cover plate and tightening screws is necessary. Specific deformation forces are necessary for the compression. The cover plate and the tightening screws are to be designed appropriately. Please request recommended values.

LEAD-IN CHAMFERS

See dimension "C" in the article list.

HOUSING RECOMMENDATIONS FOR NEW DESIGNS

| d | S (Profile) | L |
|---------|-------------|-------|
| >100 mm | 20 mm | 16 mm |
| >250 mm | 22 mm | 20 mm |
| <450 mm | 25 mm | 22 mm |
| >750 mm | 32 mm | 25 mm |